

承認書

APPROVE SHEET



敬請承認如下之形式規格書：

客戶名稱

CUSTOMER: _____

貴公司製品名

本公司製品名：

撥动开关

CUSTOMER PN: _____ PRODUCT PN: _____

貴公司規格

本公司規格：

EL-MSK53

APPROVAL DAT: _____ PRODUCT CODE: _____

客戶料號：

本公司規格書編號：

CUSTOMER NO.: _____ PRODUCT DRAWING NO.: _____

新品承認

NEW APPROVE

規格變更再承認

CHANGE CODE APPROVE

AGAIN

材料變更再承認

CHANGE MATERIAL APPROVE

AGAIN

APPROVAL

批准

DATE:

CHECK

審查

DATE:

DESIGN

設計

DATE:

貴公司承認欄

APPROVAL SIGNATURES

請於____年____月____日前承認返回

日期 DATE: _____

PLEASE RETURN TO ADMIT XUNIANRURI

深圳市亿利百斯特电子有限公司

ShenZhen ElyBest Electronics Co., Ltd

付文鹏 (Vincent Fu)

Tel : 0755-28213003

Fax: 0755-85215085

Mob: 18923844556

Email : vincent@elybest.com

Add : 深圳市龙岗区平湖街道世之鼎产业园B栋220

		文件编号	
		发布日期	2015年04月10日
SPECIFICATION 规格书		第2版	1of2
产品名称: 拨动开关		产品型号: EL-MSK53-G2	
1: GENERAL SPECIFICATION 基本事项			
1.1	RATING (额定值): DC 12V 100mA		
1.2	PRACTICAL TEMPERATURE RANGE: -10°C~+50°C. 使用温度范围: 在-10°C~+50°C温度内使用.		
1.3	STANDARD ATMOSPHERIC CONDITIONS : UNLESS OTHERWISE SPECIFIED. THE STANDARD RANGE OF ATMOSPHERIC CONDITIONS FOR MAKING MEASUREMENTS AND TESTS ARE AS FOLLOWS: (1) AMBIENT TEMPERATURE : 5°C TO 35°C; (2) RELATIVE HUMIDITY : 45% TO 85%; (3) AIR PRESSURE : 86Kpa TO 106Kpa. 测试标准状态: 在没有指定的情况下测试温度, 湿度, 气压如下: (1) 温度为5~35°C; (2) 湿度为45~85%; (3) 气压为86Kpa~106Kpa.		
2. ELECTRICAL CHARACTERISTICS (电气性能规格):			
ITEM 项目	TEST CONDITIONS 测试条件		PERFORMANCE (DATA) 规格(数据)
2.1	CONTACT RESISTANCE 接触电阻	MEASURED AT 1KHz SMALL CURRENT (100 mA OR LESS) 在1KHz微小电流(100mA 以下)测试.	100mΩ MAX. 100毫欧以下.
2.2	INSULATION RESISTANCE 绝缘电阻	APPLY A VOLTAGE OF 100V DC FOR 1 MIN. THE FOLLOWING CONTACT TEST METHOD: (1) BETWEEN BODY AND CONDUCTOR. (2) BETWEEN CONDUCTORS NOT TO BE CONTACT. 输入100V DC电压1分钟, 按以下接触方法测试: (1) 接触端子之间. (2) 胶座体和排脚之间.	50MΩ MIN. 50兆欧以上.
2.3	ELECTRIC STRENGTH 耐电压	AC 250V (50-60Hz) FOR 1 MIN TRIP CURRENT: 0.5mA THE FOLLOWING CONTACT TEST METHOD: (1) BETWEEN TERMINALS. (2) BETWEEN INDIVIDUAL TERMINALS AND FRAME. 输入AC250V (50-60Hz) 电压, 1分钟感度电流为0.5mA, 接触测试方法如下: (1) 接触端子之间. (2) 外壳体和排脚之间.	WITHOUT DAMAGE TO PARTS ARCING OR BREAKDOWN ETC. 没有绝缘破坏等异常
3. MECHANICAL CHARACTERISTICS (机械性能规格)			
ITEM 项目	TEST CONDITIONS 测试条件		PERFORMANCE (DATA) 规格(数据)
3.1	OPERATION FORCE 动作力	LATERAL PUSH (侧向推动)	PUSH FORCE (按压力度): 200gf ± 50gf
3.2	TRAVEL TO CLOSURE 动作行程	IN THE HORIZONTAL DIRECTION SWITCH HANDLE OPERATION, WITH AN EQUAL TO 2TIMES THE THRUST OF THE SWITCH FROM ONE POSITION TO THE NEXT GEAR, MOVING DISTANCE MEASURING HANDLE. 在开关推柄运行的水平方向, 以一个等于2倍推力使开关从一个档位运动到下一档位, 测量推柄的移动距离.	2mm ± 0.2mm
3.3	STEM STRENGTH 操作部(柄)强度	AND ALONG THE RUNNING DIRECTION AT APEX HANDLE (500g) ON THE STRENGTH TEST, TIME IS 30 SECONDS. 在推柄的先端沿运行方向加上(500g)力度测试, 时间为30秒.	外观无异常, 满足于机械, 电气性能
PREPARED 制定: 郭政		CHECKED 核对: 倪云鹏	APPROVED 审批: 林志明

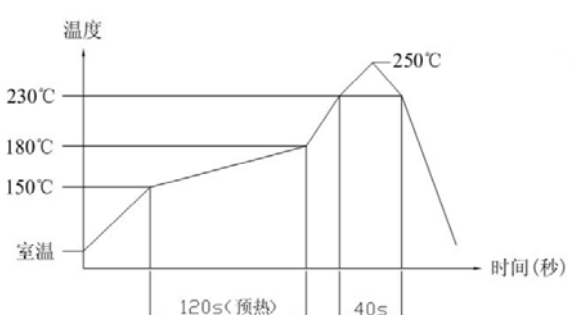
		文件编号	
		发布日期	2015年04月10日
SPECIFICATION 规格书		第2版	2of2
产品名称: 拨动开关		产品型号: EL-MSK53-G2	
4. DURABILITY(耐久性):			
ITEM 项目	TEST CONDITIONS 测试条件		PERFORMANCE (DATA) 规格(数据)
4.1	LIFE TEST 寿命试验	AN ACTUATOR SHALL BE WITH A THRUST OF NO GREAT THAN 1 TIMES SWITH POWER TO 5000-10000 CYCLES AT A SPEED OF 30 CYCLES FOR 1 MIN. 操作者以每分钟30次的频率, 施加不大于开关1倍的推力做5000-10000次无负荷测试.	1) CONTACT RESISTANCE SHALL BE >300mΩ. 2) LIFETIME: 5000-10000次 1) 接触电阻 > 300mΩ. 2) 寿命: 5000-10000次
4.2	HEAT TEST 耐热实验	THE SWITCH SHALL BE STORED AT A TEMPERATURE OF 85±2°C FOR 96 HOURS. AND THEN IT SHALL BE SUBJECTED TO THE CONTROLLED RECOVERY CONDITIONS FOR 1 HOUR AFTER WHICH MEASUREMENT SHALL BE MADE. 放置在温度85±2°C中96小时后, 再放置正常室温中1小时后测定.	THERE SHALL BE NO DAMAGE ON APPEARANCE. MECHANICAL AND ELECTRICAL CHARACTERISTICS SHALL BE SATISFIED. 外观无异常, 满足于机械, 电气性能
4.3	COLD TEST 耐冷实验	THE SWITCH SHALL BE STORED AT A TEMPERATURE OF -25±3°C FOR 96 HOURS. AND THEN IT SHALL BE SUBJECTED TO THE CONTROLLED RECOVERY CONDITIONS FOR 1 HOUR AFTER WHICH MEASUREMENT SHALL BE MADE. 放置在温度-25±3°C中96小时后, 再放置正常室温中1小时后测定.	
4.4	HUMIDITY TEST 潮湿实验	THE SWITCH SHALL BE STORED AT A TEMPERATURE OF 40±2°C AND A HUMIDITY OF 80% TO 85% FOR 96 Hr. THEN THE JACK SHALL BE MAINTAINED AT STANDARD ATMOSPHERIC CONDITION FOR 1 Hr FOR OTHER PROCEDURES. 放置在40±2°C相对湿度为80~85%环境中96小时后, 再将样品放在正常室温中1小时后测定.	
4.5	SOLDERING CONDITIONS 焊锡条件	1) HAND SOLDERING 手焊: DVICE 工具: SOLDER IRON 电烙铁. 270°C MAX., 3 sec Max 2) REFLOW SOLDERING 回流焊: ≤250°C  <p>The graph shows a temperature profile for reflow soldering. The y-axis is labeled '温度' (Temperature) and the x-axis is '时间(秒)' (Time in seconds). The profile starts at '室温' (Room Temperature), rises to 150°C, then to 180°C, and finally to a peak of 250°C. A horizontal line at 150°C is labeled '120s(预热)' (120s preheat). A horizontal line at 250°C is labeled '40s'. The temperature then decreases back to room temperature.</p>	
PREPARED 制定: 郭政		CHECKED 核对: 倪云鹏	APPROVED 审批: 林志明

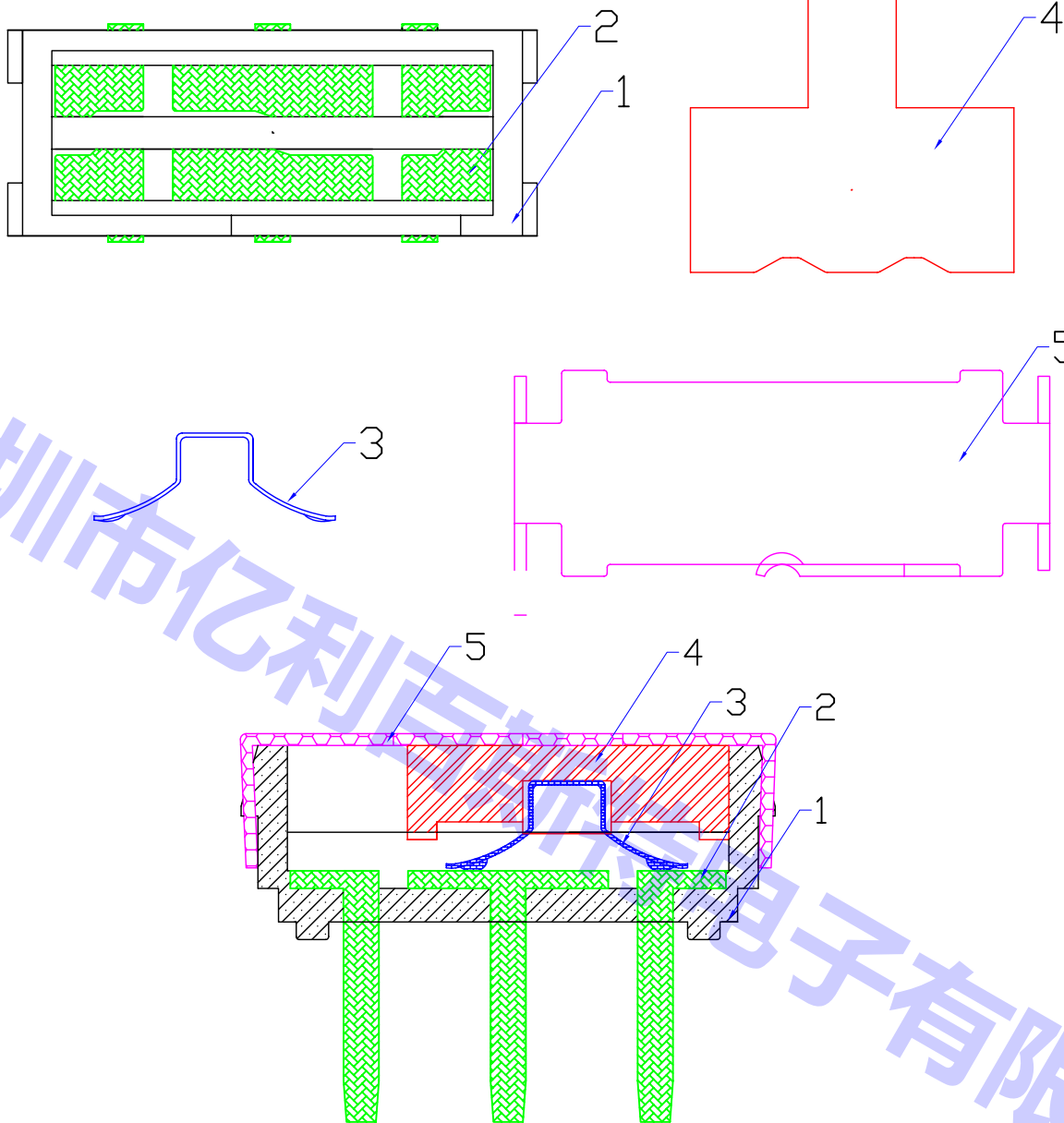

项目	零件	材料	颜色	数量
1	塑胶本体	PA6T	黑色	1
2	五金端子	磷铜镀银	银白色	6
3	接触簧片	铍青铜镀银	银白色	2
4	塑胶推柄	PA46	黑色	1
5	五金盖板	不锈钢	本色	1
6				

制定	核对	审批	日期	备注	此数据仅供参考，实际以样品为准
郭政	倪云鹏	林志明	2015.04.10		

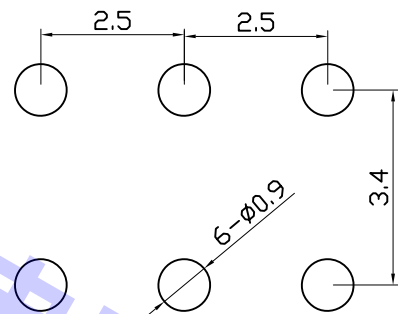
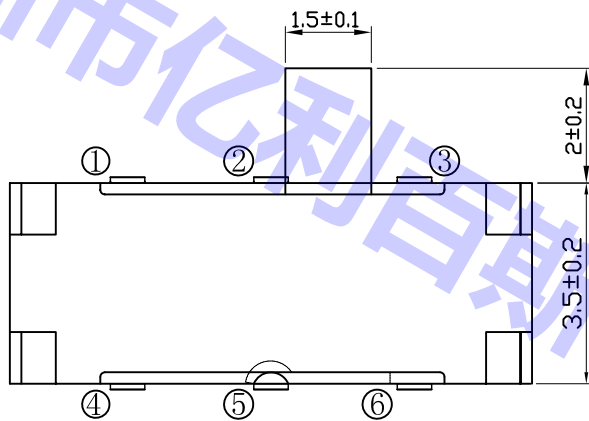
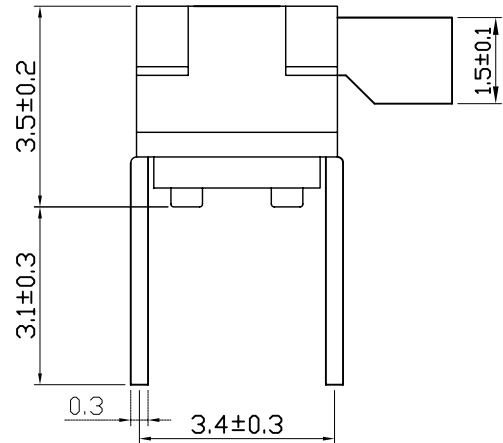
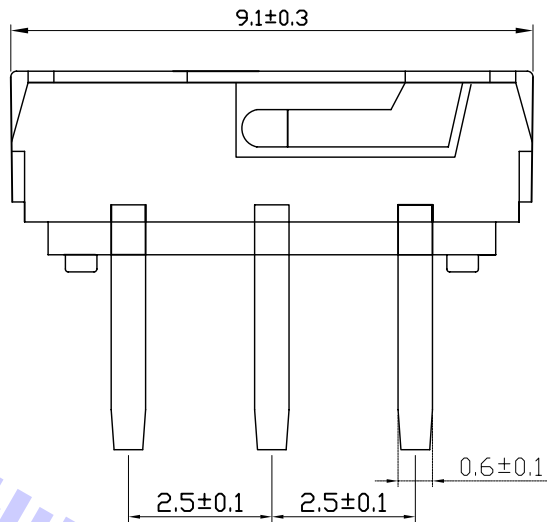

安装图 (PCB LAYOUT PLAN)

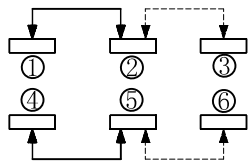

电路图 (CIRCUIT DIAGRAM)

LENGTH	TOLERANCE
L < 5	
5 ≤ L ≤ 10	
10 < L ≤ 15	
15 < L	

型号

推柄长度

底座颜色

推柄颜色

动作力 (gf)

寿命

EL-MSK53-G2

2.0MM

黑色

黑色

200gf ± 50gf

5000-10000次



深圳市亿利百斯特电子有限公司
ShenZhen ElyBest Electronics Co., Ltd

备注

比例 1:1

制定

核对

审批

日期

尺寸单位

郭政

倪云鹏

林志明

2015.04.10

mm

此数据仅供参考，实际以样品为准